

BBS



BBS

BBS – brief history

1972 – BBS established to process and clear paper based giro payments

1988 – BBS selected as national ACH and single channel to the banks accounts in the Central Bank

1992 – Bank-Axept established as national efpos processor

1995 – BBS and Bank-Axept merged.



BBS

BBS – key figures

No. of employees as on 31st of December 2005:

694

Operating income in the year 2005:

NOK 1.472 million

Profit before tax 2005:

NOK 110 million

Share capital as on 31.12.05:

NOK 165 million

Total amount cleared in the year 2005:

NOK 49.800 billion

Total number of cleared transactions in 2005:

1.238 millions



BBS

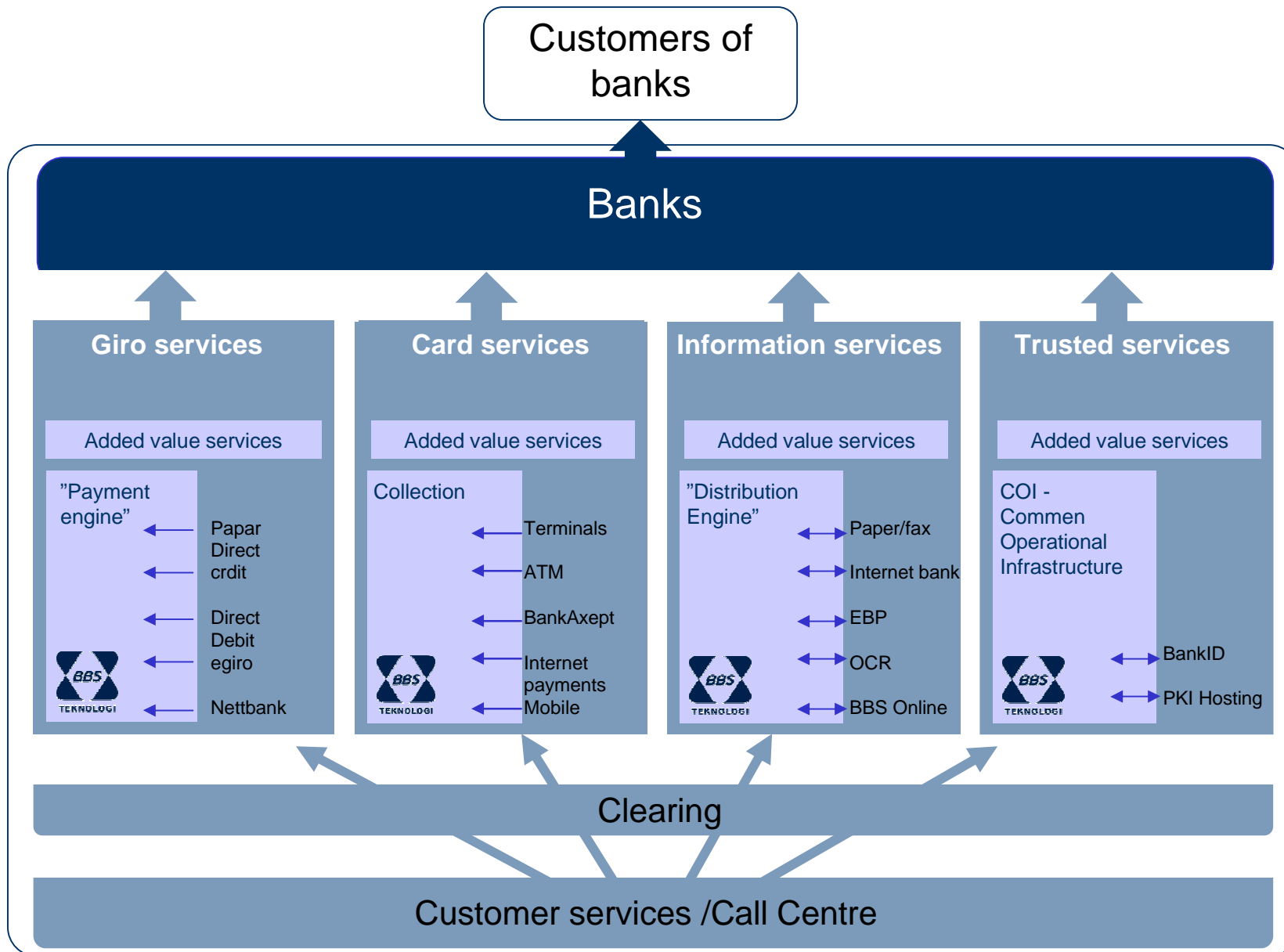

Transactions

BBS, 1997 – 2005 (NOK million)

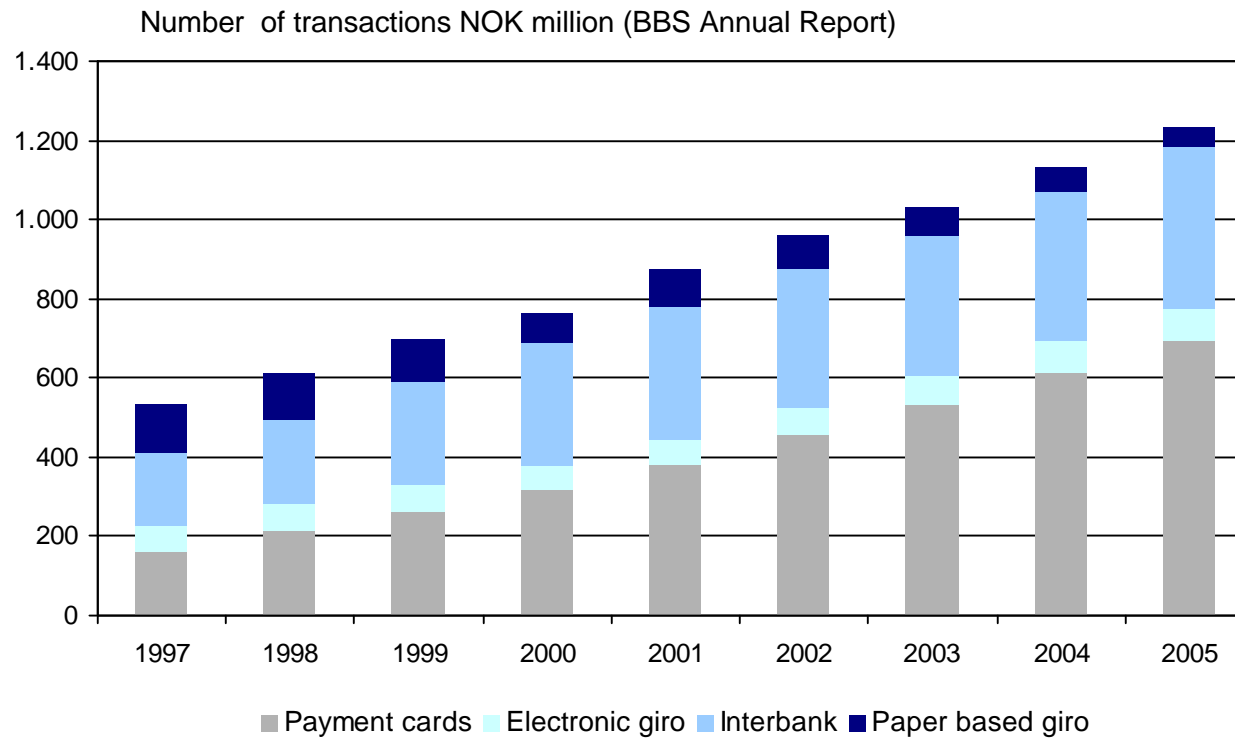

BBS

Transaction breakdown internationally

- Norway leads the world in general* card usage
- A factor enhancing high card and giro use is a common infrastructure. This is a distinctive feature of the Nordic countries.

Transaction type broken down by country (Source: Central Bank of Norway)

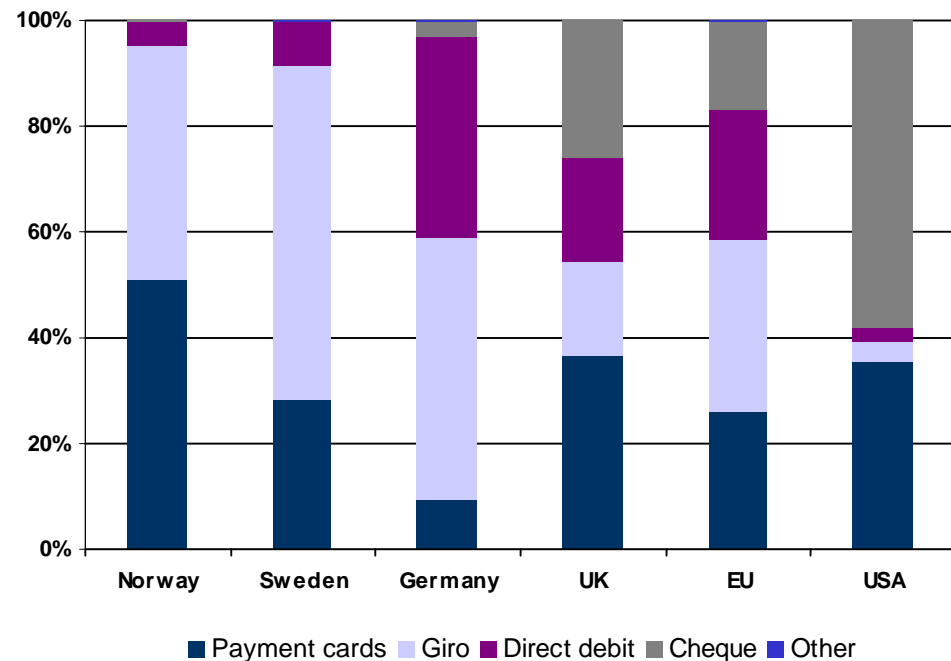

*) All kinds of card usage



NICS (Norwegian Interbank Clearing System)

- The joint system for clearing high value- and mass payments between banks, with settlement at the banks account in the Central Bank.
- NICS operates under licence from the Central Bank with the the two bankers associations as the licensee on behalf of all participating banks.
- BBS is the operator for NICS under agreement with the two associations.



BBS

A new “Payment engine” being introduced at BBS

- New payment engine suited to private and corporate internet banks.
- Bank customer communicates with payment engine via bank’s internet bank.
- Reuses payment infrastructure in BBS.
- Broad spectrum of payment functions
- Consists of APLs, not web fronts

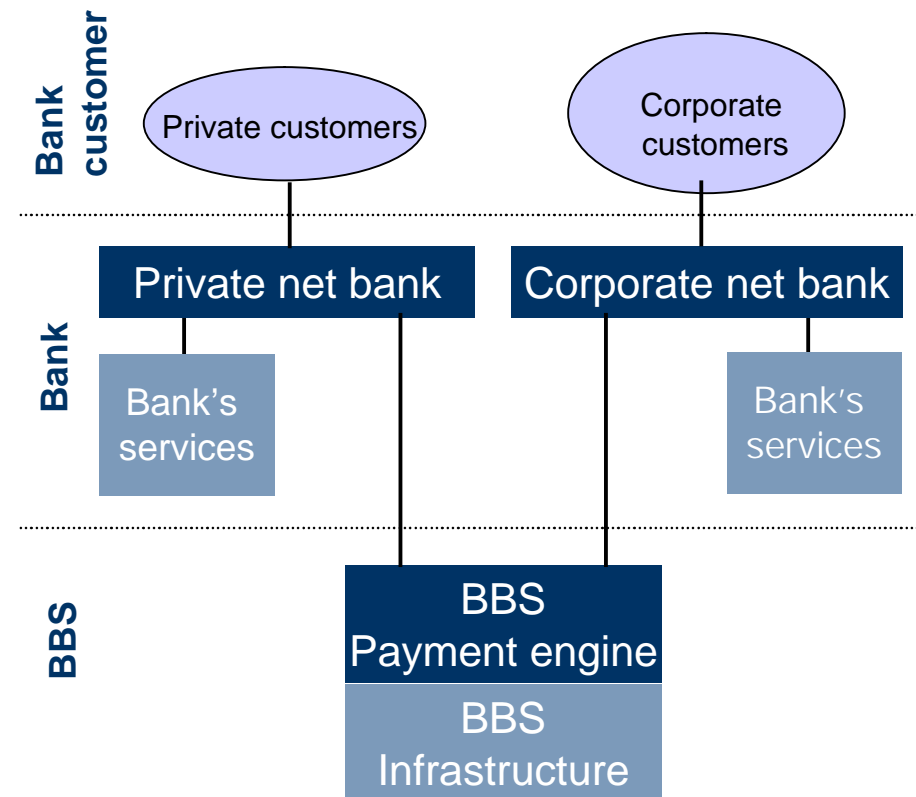

BBS

BBS – Nonstop systems

- All systems are connected with ServerNet.
- Every critical “thing” is duplicated at backup site
- Mirrored systems have the same disk configurations
- We change production site 4-5 times a year.



Eftpos system (Sofie) today.

0/1	2/3	4/5	6/7	8/9	10/11
72	72	72	72	72	74



BBS

Eftpos system (Sofie) on NS16

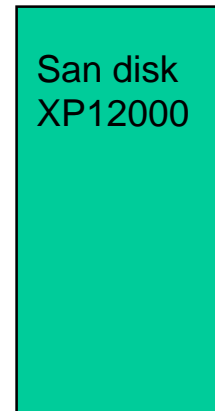
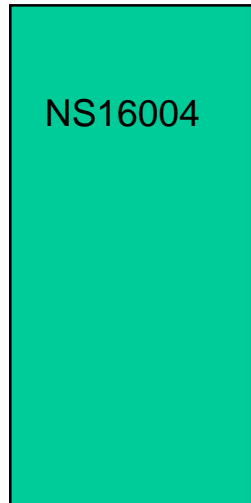

Software

- RDF
- Autosync/AutoTmf
- ICE
- MQ



HP NonStop Systemer 27.04.06

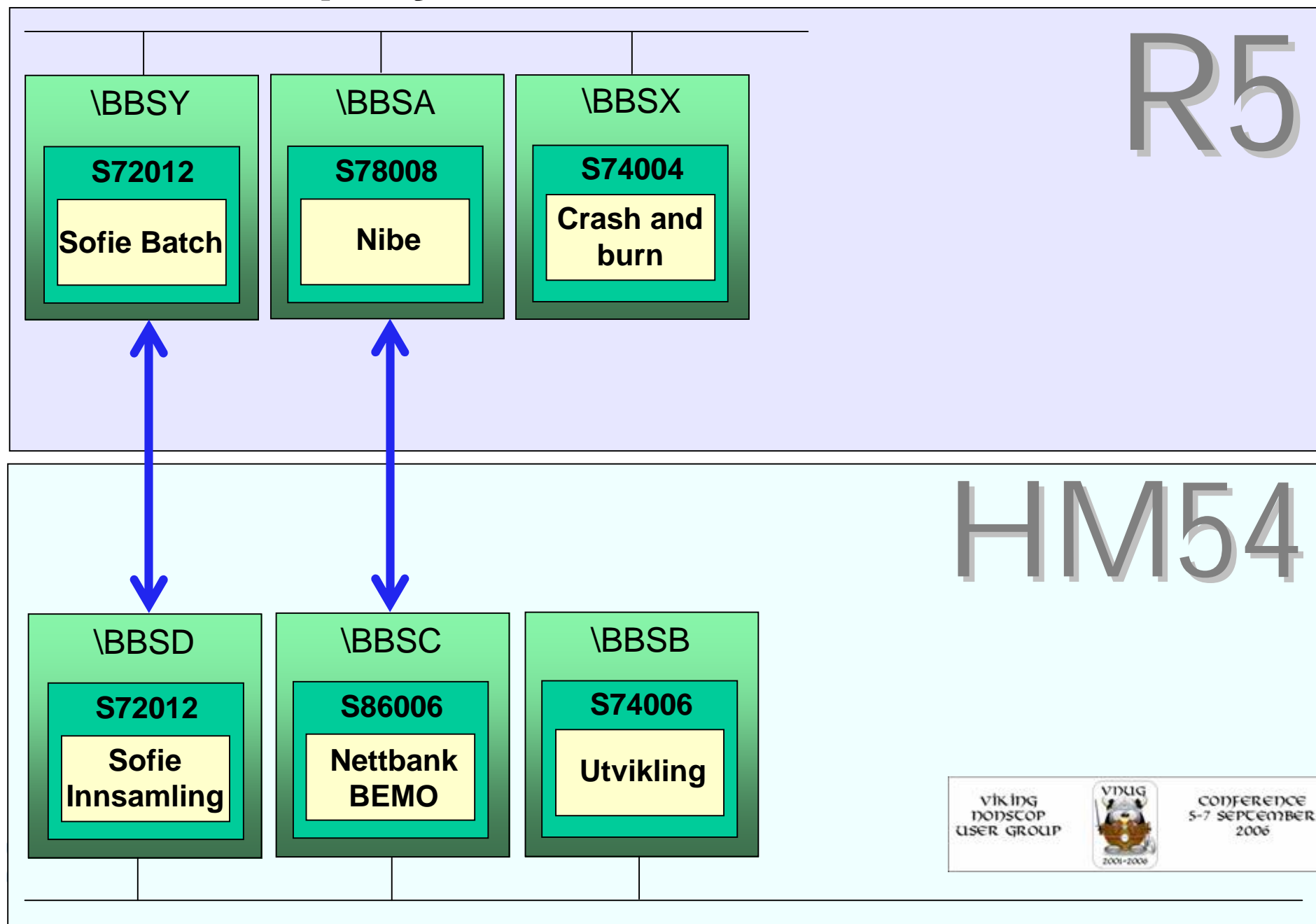

HP NonStop Systemer 10.05.06

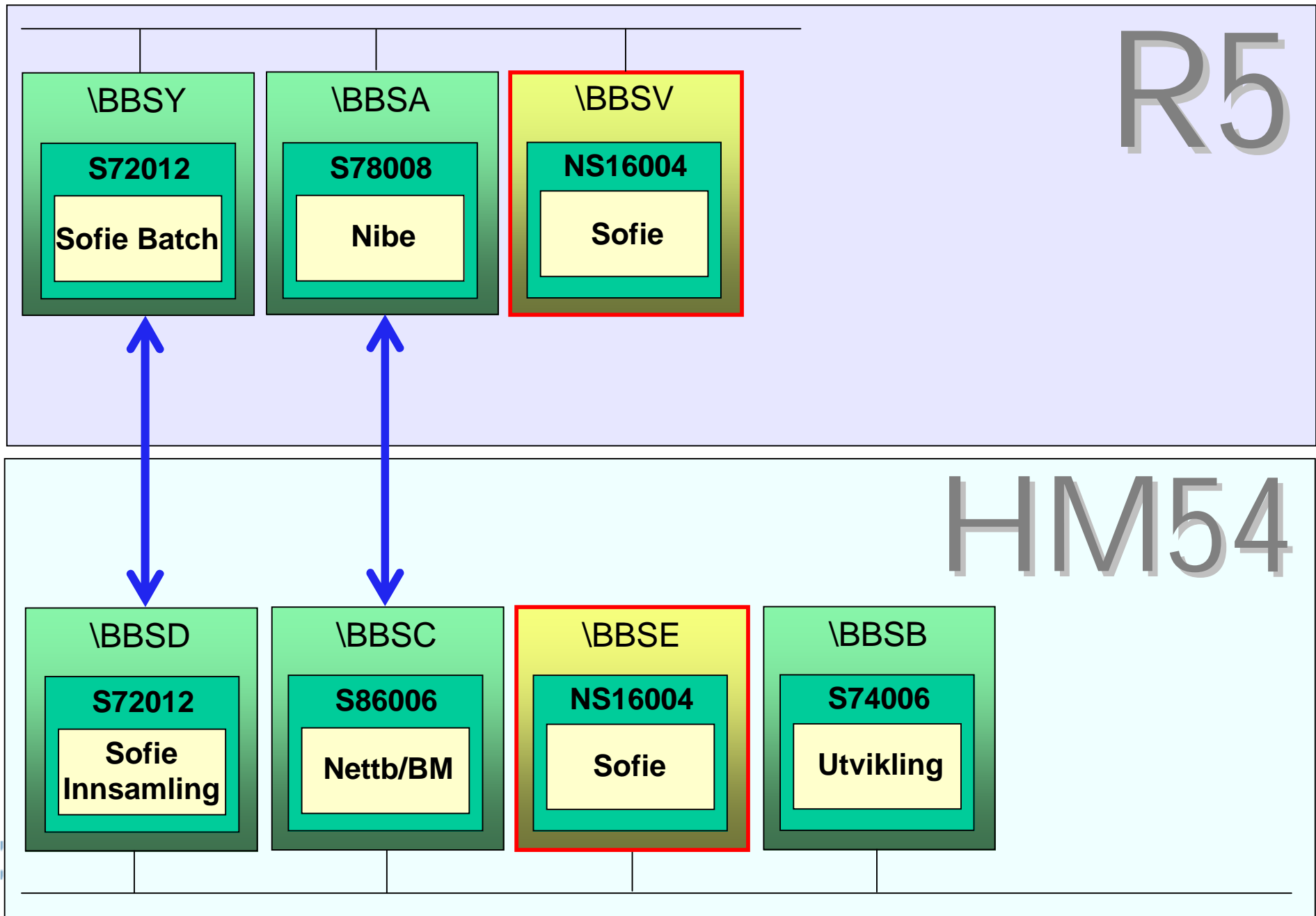

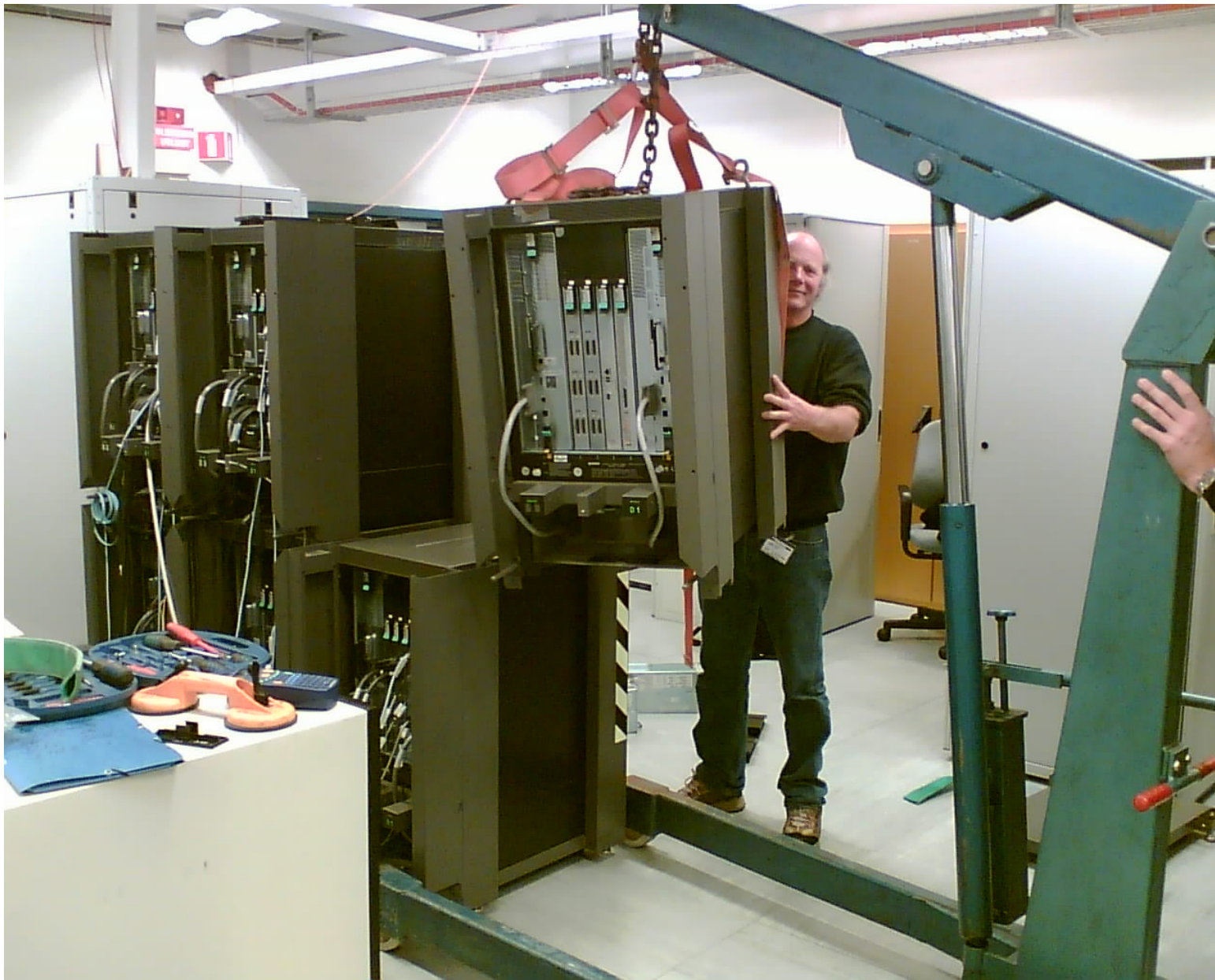

BBS

HP NonStop Systemer 15.06.06

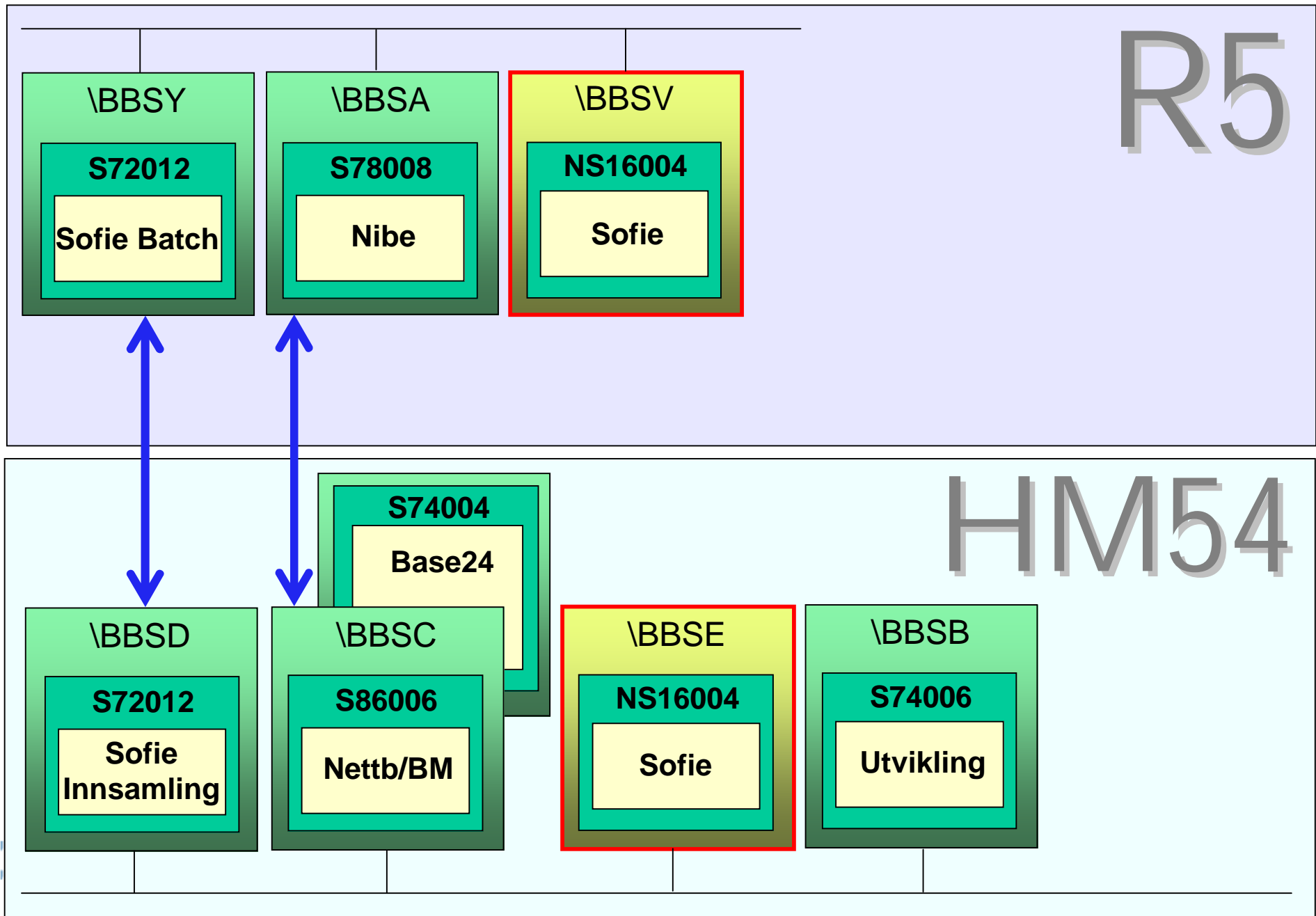

HP NonStop Systemer 15.09.06

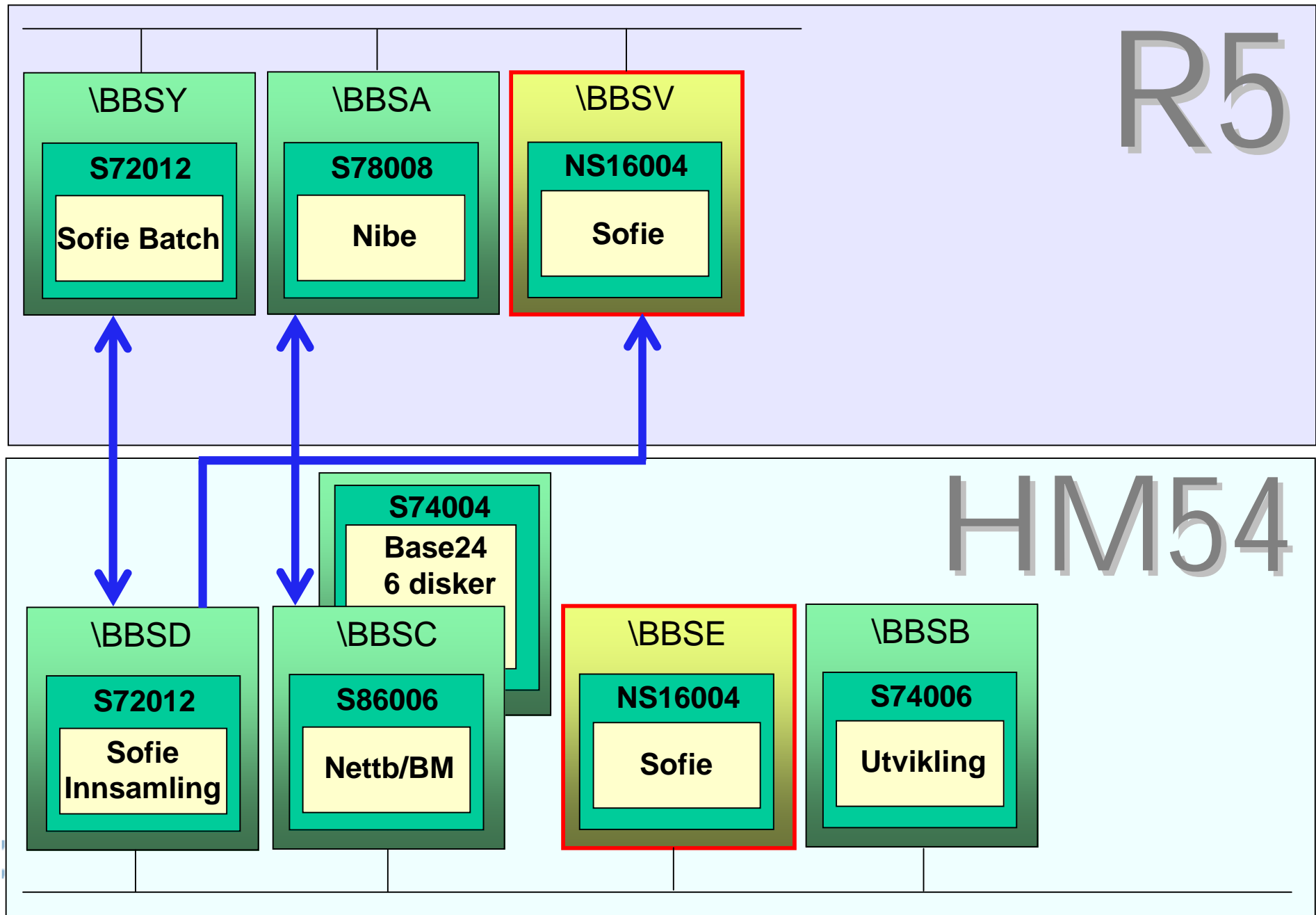

HP NonStop Systemer 15.10.06

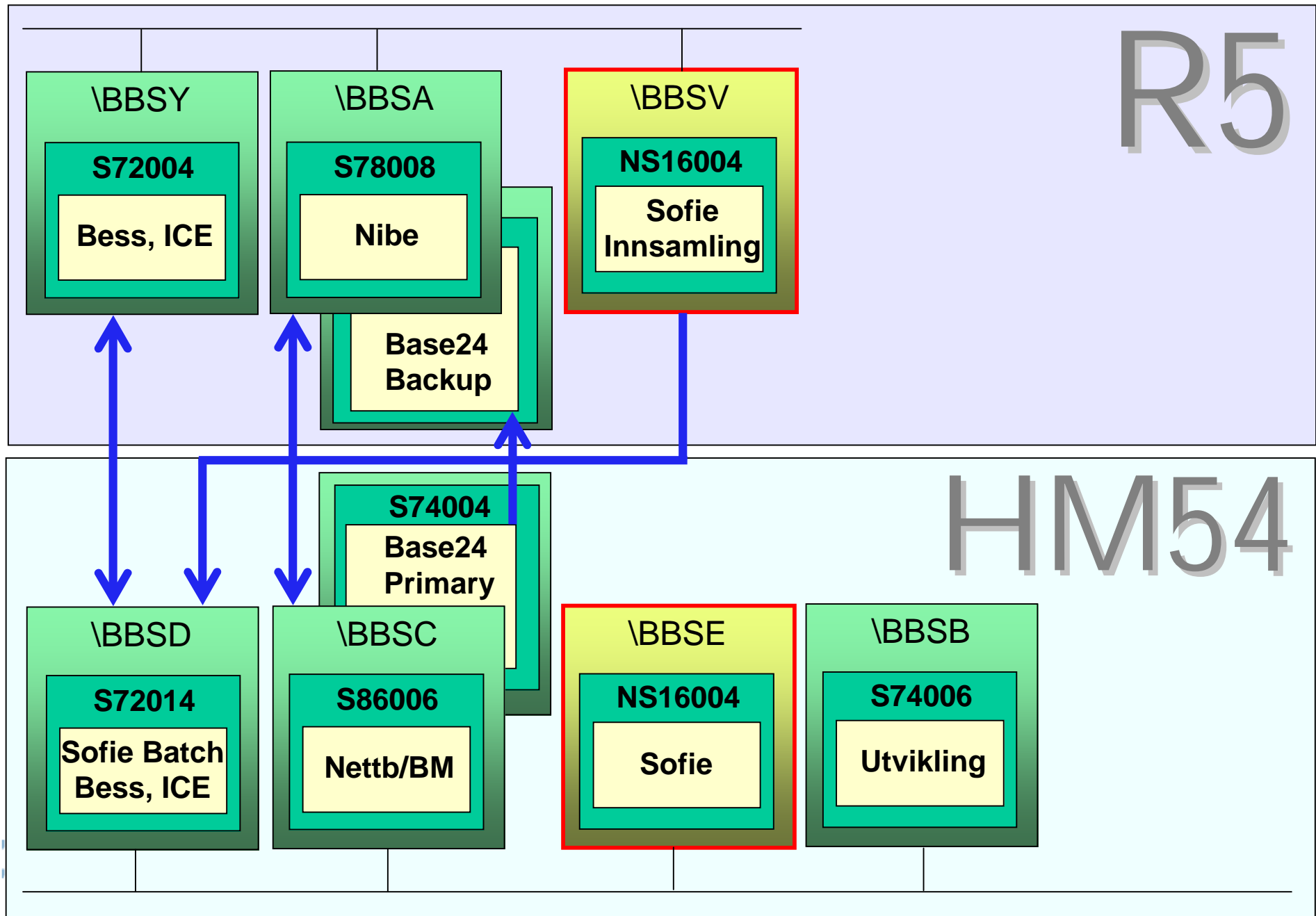

HP NonStop Systemer 01.02.07

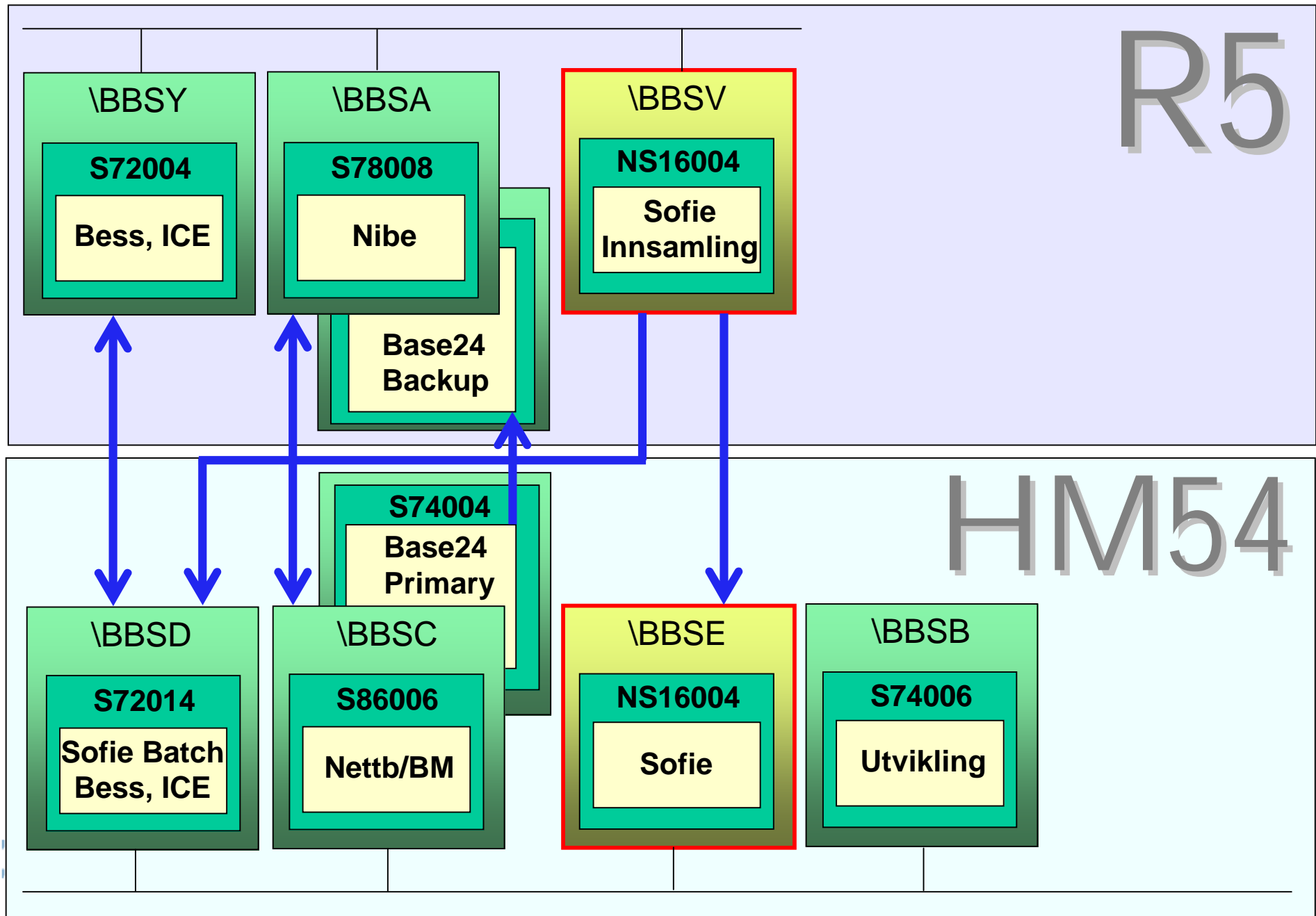

HP NonStop Systemer 15.03.07

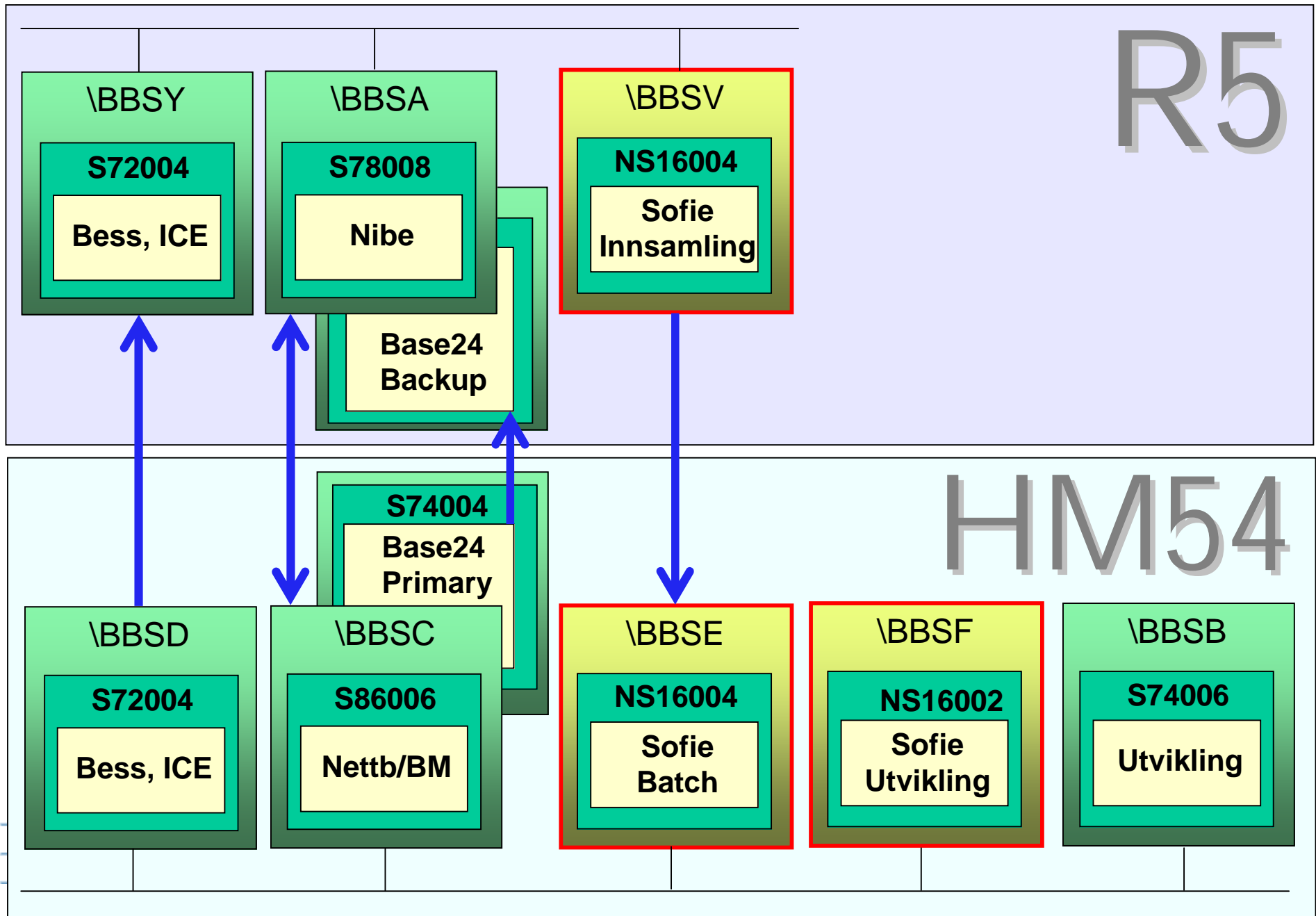

”The best way to predict
the future is to invent it”

– Alan Kay



BBS